

DINO-DIRIS®

Clapet à Battant

**Réf :
220 103**

ACIER

» MÉTAL / MÉTAL
» DIN 3202 F1

» BRIDES
» ISO PN40

» TMS : 400°C (1)
» PMS : 40B

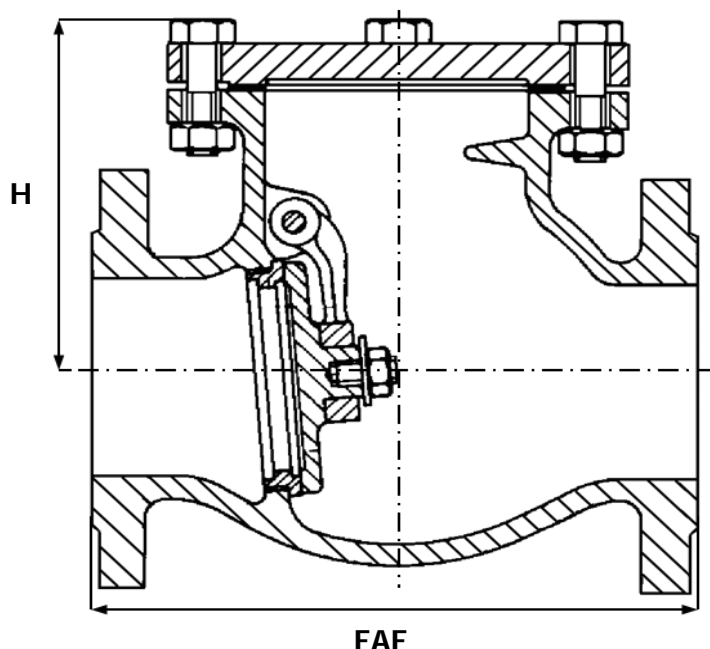

CORPS / BODY	ACIER GSC 25
CHAPEAU / BONNET	ACIER GSC 25
BATTANT / DISC	ACIER GSC 25
SIÈGES / SEATS	INOX F6
JOINT / GASKET	GRAPHITE

DN	8	10	15	20	25	32	40	50	65	80	100	125	150	200	250	300	350	400	450	500	600	
INCHES	1/4"	3/8"	1/2"	3/4"	1"	1 1/4"	1 1/2"	2"	2 1/2"	3"	4"	5"	6"	8"	10"	12"	14"	16"	18"	20"	24"	
FAF								230	290	310	350	400	480	600	730	850	980	1100			1250	1450
H								125	150	160	175	230	270	355	395	470	520	600			670	760
MASSE								17	30	34	48	105	118	220	320	450	600	800			1270	1800

Unités : mm, Kg.